

## Stationary cathodic current measurements in a thin layer cell: application to mass transport study in confined mediums.

E. Remita, E. Sutter, B. Tribollet, F. Ropital, X. Longaygue, Carol Taravel-Condat, N. Desamais

► **To cite this version:**

E. Remita, E. Sutter, B. Tribollet, F. Ropital, X. Longaygue, et al.. Stationary cathodic current measurements in a thin layer cell: application to mass transport study in confined mediums.. Eurocorr 2006, Sep 2006, Maastricht, Netherlands. hal-02475668

**HAL Id: hal-02475668**

**<https://hal-ifp.archives-ouvertes.fr/hal-02475668>**

Submitted on 12 Feb 2020

**HAL** is a multi-disciplinary open access archive for the deposit and dissemination of scientific research documents, whether they are published or not. The documents may come from teaching and research institutions in France or abroad, or from public or private research centers.

L'archive ouverte pluridisciplinaire **HAL**, est destinée au dépôt et à la diffusion de documents scientifiques de niveau recherche, publiés ou non, émanant des établissements d'enseignement et de recherche français ou étrangers, des laboratoires publics ou privés.

# STATIONARY CATHODIC CURRENT MEASUREMENTS IN A THIN LAYER CELL: APPLICATION TO MASS TRANSPORT STUDY IN CONFINED MEDIUMS

E. REMITA<sup>1</sup>, E. SUTTER<sup>2</sup>, B. TRIBOLLET<sup>3</sup>, F. ROPITAL<sup>1</sup>, X. LONGAYGUE<sup>1</sup>, C. CONDAT-TARAVEL<sup>4</sup>, N. DESAMAIS<sup>4</sup>

<sup>1</sup>*Institut Français du Pétrole, 1 avenue de Bois Preau 92852 Rueil Malmaison France*

<sup>2</sup>*Laboratoire de Génie des Procédés Plasma et Traitement de Surface, 11 rue Pierre et Marie Curie  
75005 Paris France*

<sup>3</sup>*Laboratoire Interfaces et Systèmes Electrochimiques, UPR15 du CNRS, case 133 4 place Jussieu  
75252 Paris Cedex 05 France*

<sup>4</sup>*Technip-Flexifrance, rue Jean Huré 76580 Le Trait France*

## ABSTRACT

In many practical situations, electrochemical processes occur within restricted volumes of electrolyte. This case is notably encountered during the corrosion of the armour steel wires in the annulus space of flexible offshore pipelines (V/S values would be in the order of 0.03 mL/cm<sup>2</sup>). In such small electrolyte volumes, it has been widely reported that the results classically obtained in bulk conditions (infinite electrolyte volume) do not necessarily remain valid. However, to our knowledge, the continuous monitoring of well controlled corrosion experiments in similar conditions as those encountered in the annulus (V/S, CO<sub>2</sub>/H<sub>2</sub>S) remains unrealised.

In order to investigate the influence of confinement on the corrosion behaviour of metallic materials, an innovative thin layer electrochemical cell was developed. This cell includes a device which allows a continuous gas supply within the electrolyte film covering the metallic specimen under study. A methodology based on high frequency impedance measurements is also proposed to control and precisely adjust the setting of the electrolyte film geometry.

The experimental setup was validated by performing measurements of stationary limiting cathodic current on a steel disk immersed in a K<sub>2</sub>SO<sub>4</sub> aerated solution for various electrolyte layer thicknesses. The results obtained demonstrate the efficiency of the gas supply method and the high accuracy of the positioning procedure.

This work provides an improved thin-layer electrochemical cell suitable for further studies dealing with the corrosion behaviour of steels in confined electrolytes as for instance acidic aqueous solutions encountered in the oil and gas industry.

## I. INTRODUCTION

In oil and gas industry, offshore flexible pipelines are more and more widespread elements for the transport of crude oils on the sea bottom (flowlines) and then to the topside equipments (risers). Easy to install, these pipes are notably well adapted to deep water production. The main elements which constitute the structure of flexible pipes are depicted in figure 1.

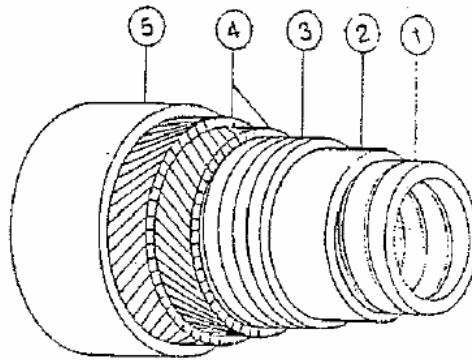

*Figure 1 : Flexible pipeline cross section*

With :

1. An interlocked internal carcass usually made of stainless steel. Its purpose is mainly to prevent collapse of the inner sheath due to the high hydrostatic pressure. This carcass is not leak-tight against gas and liquid.
2. An inner polymer sheath which seals the bore. Depending on the field temperature conditions, this polymer layer is made of P.E., polyamide 11 or PVDF.
3. One or two layers of pressure armours.
4. Two layers of cross wound wires to give the pipe axial strength (tensile armours).
5. An outer plastic sheath for sealing and protection of the inner metallic components.

The annulus is defined as the space located between the two polymer sheaths (marked 2 and 5 on figure 1).

During the pipe service, the annulus is progressively filled by an electrolyte which is generally condensed water (as a result of water permeation through the inner sheath) or more rarely sea water (in case of accidental tearing of the outer sheath). Acid gases contained in the crude oil ( $\text{CO}_2/\text{H}_2\text{S}$ ) also permeate into the annulus through the inner sheath. In these conditions, the armouring wires present in the annulus could corrode uniformly. As a corrosive environment, the annulus is however quite specific because of the severe confinement of the electrolyte. Indeed, the ratio V/S between the volume of electrolyte and the exposed metallic surface is typically in the order of  $0.03 \text{ mL/cm}^2$  inside the annulus [1].

Past corrosion studies reported that corrosion rates of metals covered by thin electrolyte films could be radically different from those encountered in bulk conditions (infinite electrolyte volume) [1-5]. The dependence of corrosion rates on electrolyte

film thicknesses was notably stated by Stratman and al. [6] in the case of atmospheric corrosion and by Ropital and al. in the case of CO<sub>2</sub>/H<sub>2</sub>S corrosion [2]. At 20°C, in an electrolyte saturated with CO<sub>2</sub> ( $P_{\text{CO}_2} = P_{\text{total}} = 1 \text{ bar}$ ) Ropital and al. have shown in particular that CO<sub>2</sub> corrosion rates of low alloyed steel could be reduced by a factor 400 when the V/S ratio diminishes from 100 to 0.25 mL/cm<sup>2</sup>. Then, these results clearly demonstrate that the geometrical confinement of the electrolyte decreases CO<sub>2</sub> corrosion rates of steel. However, the experimental setup previously used by these authors did not allow performing well controlled corrosion experiments in confinement conditions as specific as those encountered in the annulus of offshore flexible pipelines. Hence, due to the lack of experimental data, corrosion rates in the annulus probably remain over estimated by available models.

In order to investigate corrosion processes in the annulus of offshore flexible pipelines, an innovative experimental methodology was developed. Based on the principle of a thin layer cell [7,8], the experimental set up allows confining a thin electrolyte layer between the surface of the working specimen and a waterproof polymer membrane. The set-up was designed to insure a continuous local gas supply within this liquid film. The liquid film thicknesses can be set freely in the range 50-6000 μm. In order to improve the precision of the cell, a positioning control procedure based on electrolyte resistance measurements was established. Measurements of stationary oxygen reduction currents were performed on a AISI 316 L stainless steel to validate the methodology. A simple theoretical model is proposed to explain the experimental results.

## II. EXPERIMENTAL DEVICE AND METHODOLOGY

### II.1 Description of the setup

The testing specimen is the cross section of a metallic cylinder (10 mm diameter). The metallic material used in this study is a AISI 316 L stainless steel. This sample is surrounded by three identical Pt disc electrodes which are each one the cross section of a 1 mm diameter Pt wire. These four coplanar electrodes are sealed in a cylindrical epoxy resin insulating holder (30 mm diameter). The respective locations of these electrodes are described in figure 2.

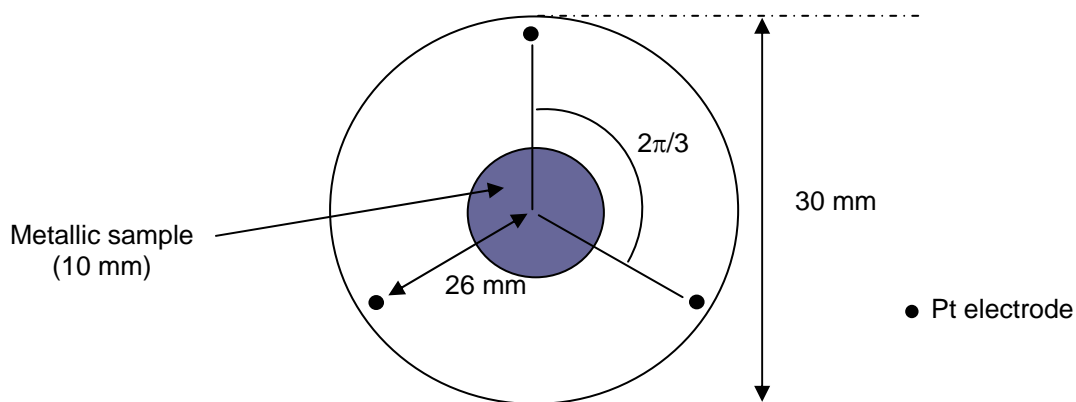

*Figure 2: top view of the multi-electrode arrangement in the cylindrical holder*

Prior to each exposure inside the cell, the electrode-arrangement was successively polished with a 4000 grit silicon carbide paper, cleaned with ethanol, rinsed with water, and dried with a N<sub>2</sub> flux.

The electrode holder described in figure 2 is embedded at the bottom of a perforated glass cell. Rubber gaskets surrounding the electrode holder prevent any electrolyte leakage at the bottom of the cell. The glass cell/electrode holder assembly is fixed on a micro-positioning system made of a bidirectional x-y translation stage mounted on a three-axis rotation platform (see figure 3). Thanks to this configuration, the position and the spatial orientation of the electrode surface can be completely defined. The micro-positioning system used in this study insures an accuracy of 10  $\mu$ rad on the angular settings and a 1  $\mu$ m precision on linear positioning.

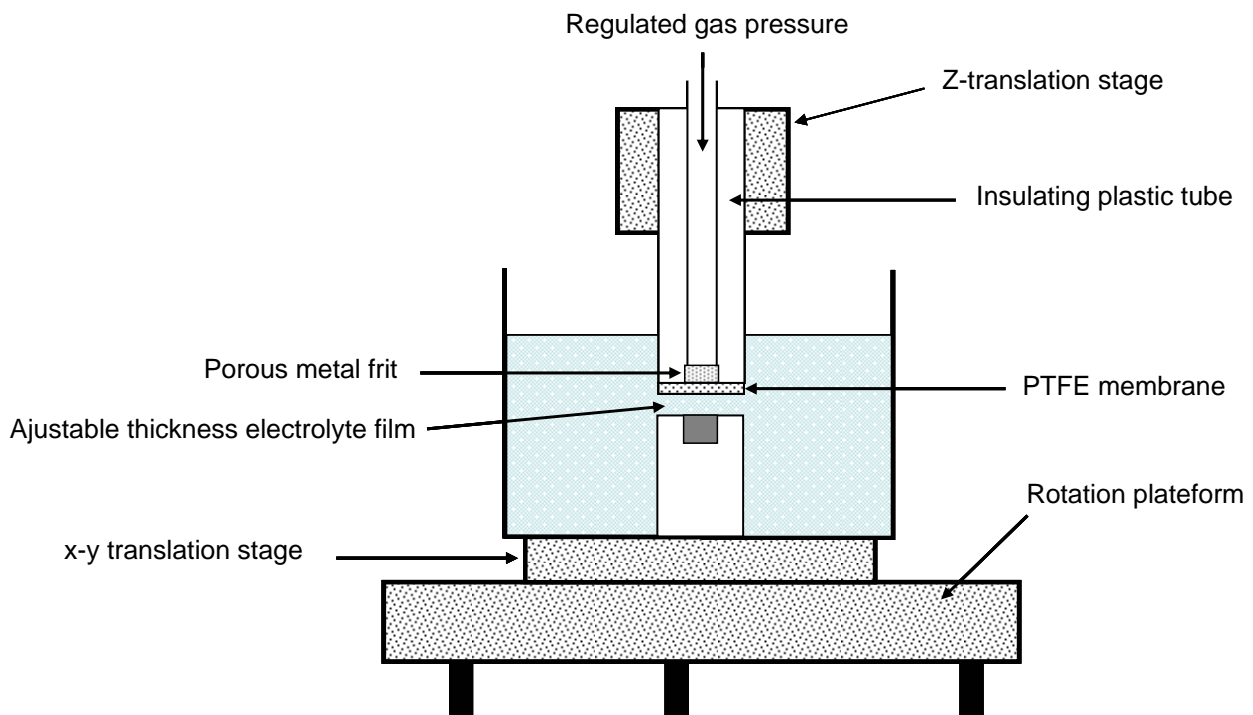

*Figure 3 : Global view of the experimental device*

Facing the multi-electrode arrangement, a mobile waterproof polymeric cylinder (30 mm diameter) insures the confinement of the electrolyte layer covering the metallic sample. The waterproof cylinder is attached to a z-translation stage and can be moved vertically with a precision of 2  $\mu$ m. This cylinder is a Plexiglas tube (30 mm external diameter) holding at its downside extremity a porous metal frit covered by a thin (35  $\mu$ m thick) PTFE hydrophobic gas permeable membrane. In this study, the PTFE membrane was in contact with ambient air on its rear face (located on the top side of the membrane) in order to allow a local air supply within the confined electrolyte layer.

The whole device is supported by an anti-vibrating table.

## II.2 Electrochemical measurements and experimental conditions

All experiments reported in the present article were performed in a 0.01 M K<sub>2</sub>SO<sub>4</sub> aqueous solution. Deionised water and pure reagents were used. A Standard Sulphate Electrode (SSE) and a large platinum grid were used respectively as reference and counter electrodes. These two electrodes were located outside the confined zone. This configuration notably prevents the counter electrode reactions from affecting the confined zone chemistry.

The equipment for electrochemical measurements consists of a classical set-up : frequency response analyser Solartron 1250 and electrochemical interface Solartron 1286 monitored by a personal computer.

Impedance measurements were successively performed on the different Pt electrodes to control the geometry of the thin layer cell (*cf. II.3 and III.1*). During each measurement, the selected Pt probe was maintained at its rest potential and a small amplitude high frequency (10 kHz) *ac* current was surimposed in order to measure the electrolyte resistance (classically defined as the high frequency limit of the modulus of the complex impedance).

Quasi-steady state polarisation curves were recorded in the oxygen reduction domain on the AISI 316L electrode (*cf. III.2*). Prior to each potential sweep, the electrode was allowed to stabilize at the potential of -1 V/SSE during 30 min. The sweep rate imposed during the measurements was 1 mV/s.

## II.3 Positioning control: multi-approach curves method

As the electrolyte film thickness could drastically affect the mass transport in confined mediums [1-4], any quantitative analysis of the results obtained under thin electrolyte film conditions required an accurate knowledge of the liquid film geometry. In particular, any spatial distribution of the electrolyte film thickness on the electrode surface could have a major impact on the polarisation curves measured within thin layer cells. As an illustration, in our cell configuration (*cf. II.1*), we calculated that an angular error of 1° between the waterproof membrane surface and the electrode surface is equivalent to an error of 260 μm on the electrolyte film thickness. Hence, the error of parallelism between the waterproof membrane surface and the electrode surface should be minimized. However, this problem of controlling the parallelism seems quasi-systematically ignored in thin layer cell literature.

In this context, a new positioning control method adapted for thin layer cells was investigated in this article. This method is based on the fact that the adimensional electrolyte admittance ( $Y_{\text{adim}}$ ) measured on a disc electrode covered by a thin electrolyte layer depends on the liquid film thickness [9].

With  $Y_{\text{adim}}$  defined as :  $Y_{\text{adim}} = \frac{\text{Re}(e)}{\text{Re}_{\text{bulk}}}$   
Re(e)            the electrolyte resistance measured for an electrolyte film of thickness *e*  
Re<sub>bulk</sub>        the bulk electrolyte resistance (infinitely thick electrolyte film)

The geometry of a thin layer cell (angles and average gap between the waterproof membrane and the metallic specimen surface) could be theoretically fully determined

by measuring the electrolyte resistance on 3 probes surrounding the specimen to investigate. In order to verify the experimental feasibility of such a positioning control method, 3 Pt probes were included in our experimental device (location of the probes described in II.1) and electrolyte resistance measurements were performed on these Pt probes for various electrolyte film thicknesses. Hence, starting from bulk conditions (several millimetres thick electrolyte film), the electrolyte resistances were measured on the three Pt probes while approaching step by step the waterproof membrane from the electrode surface, following the z axis. Then, the  $Y_{adim}$  vs  $e$  curves (approach curves) were plotted for each probe.

### III. EXPERIMENTAL RESULTS AND DISCUSSION

#### III.1 Evaluation of the positioning control procedure

A typical set of approach curves ( $Y_{adim} = f(e)$  curves) obtained during the positioning phase of the thin layer cell (as described in II.3) is presented in figure 4 and 5 (the origin of the z-axis was arbitrarily chosen).

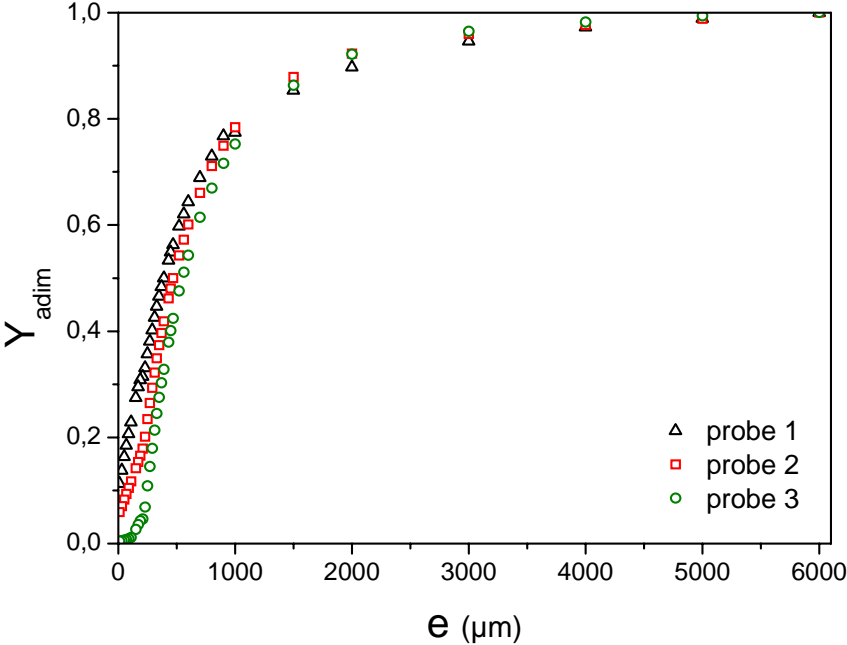

*Figure 4 : Typical set of approach curves obtained during the positioning phase of the thin layer cell*

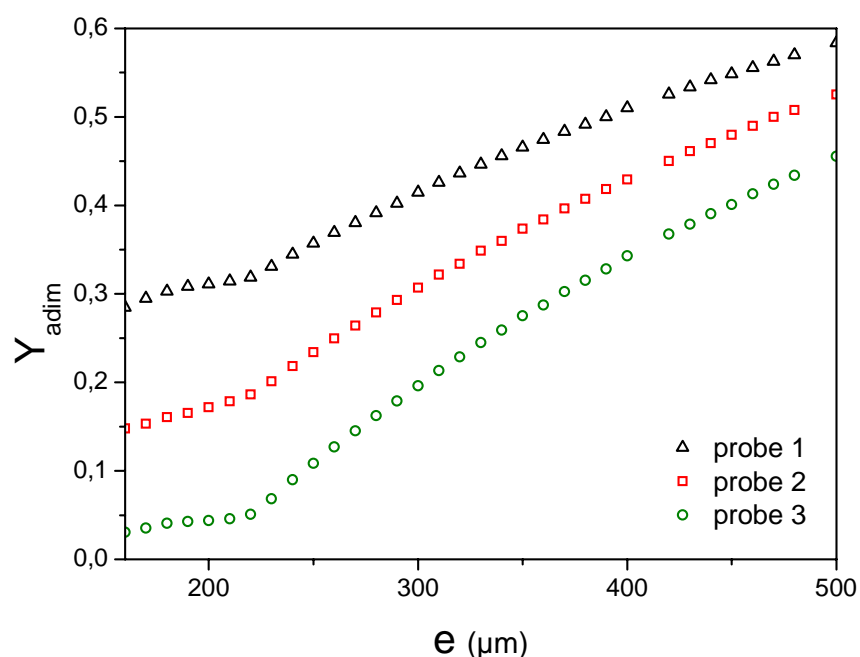

Figure 5 : Magnification of figure 4 for the low values of the electrolyte thickness

As expected from published studies, the adimensional electrolyte admittances ( $Y_{adim}$ ) increase with the electrolyte film thickness and tend asymptotically to the limiting value of 1 (which corresponds to the bulk conditions *i.e*  $Re(e) = Re_{bulk}$ ). At low electrolyte thicknesses, a well defined plateau are simultaneously reached by the 3 approach curves for the same value of  $e$  (see figure 5). This plateau behaviour can be ascribed with no ambiguity to the existence of a contact point between the waterproof membrane and the electrode holder.

At a given  $e$  value (i.e. at a given position along the  $z$ -axis), the 3 Pt probes exhibit different adimensional electrolyte admittances which reveals an electrolyte film thickness distribution in the confined zone of the thin layer cell. Hence, in the chosen example, probe 3 appears as the closest probe from the waterproof wall (lowest admittance) whereas probe 1 is the most distant from the wall. These results illustrate how parallelism errors between the waterproof membrane and the electrode arrangement surface can be sensed by the multi-approach curves method.

In order to validate the adimensional resistance measurements, “corrected” curves were plotted. These curves were obtained by translating the experimental approach curves along the  $e$ -axis and by setting the origin of this axis at the contact point  $z$ -coordinate. By choosing an adapted shift, a unique curve is obtained as shown in figure 6.



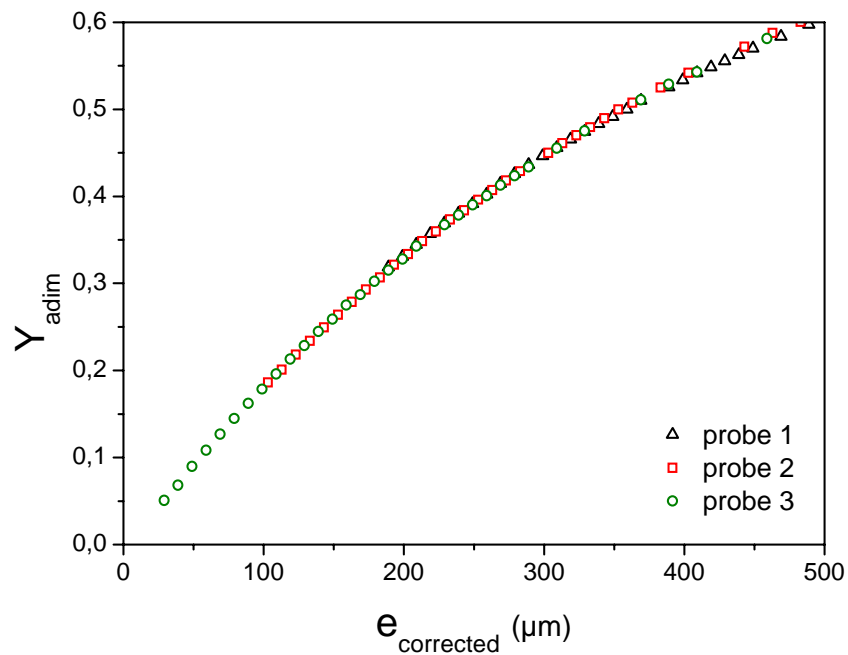

**Figure 6** : Unicity of the corrected approach curves

The unique curve obtained figure 6 is very close to the theoretical curve calculated by Gabrielli and al. in the case of a single electrode covered by a thin electrolyte film [7]. This agreement between measurements and theory validates the measurement procedure and allows quantitative interpretations of the results. Indeed, the relative gap along the z-axis between 2 probes can be determined by the thickness correction necessary to superpose the two corresponding approach curves. Then, from a practical point of view, by giving the contact point coordinate and the relative position of the different Pt probes along the z-axis, the multi-approach curves method allows a full determination of the thin electrolyte layer geometry. Moreover, the average film thickness and the eventual lack of parallelism between the waterproof membrane and the sample surface could be corrected thanks to this positioning control procedure.

Thanks to the multi-approach curves method, the estimated precision of the electrolyte thicknesses measurement is  $\pm 10 \mu\text{m}$ . This global uncertainty arises from the uncertainty concerning the determination of the contact point coordinates from the approach curves and from the slight fluctuation of  $R_e$  with time during measurements. As a comparison, repeated measurements have shown that errors of  $\pm 60 \mu\text{m}$  on the average electrolyte thickness are common when the settings (parallelism and contact point) are only visually controlled.

### III.2 Validation of the experimental device: measurements of the limiting oxygen mass transport current.

To quantify the efficiency of the gas supply system and the accuracy of the electrolyte film geometry setting, quasi-stationary polarisation curves were plotted in the oxygen reduction domain. During the measurements, the waterproof membrane was exposed to ambient air on its rear face (see II.1). The evolution of the polarisation curves with the average electrolyte film thickness (measured by the positioning procedure previously described in III.1) is presented figure 7 :

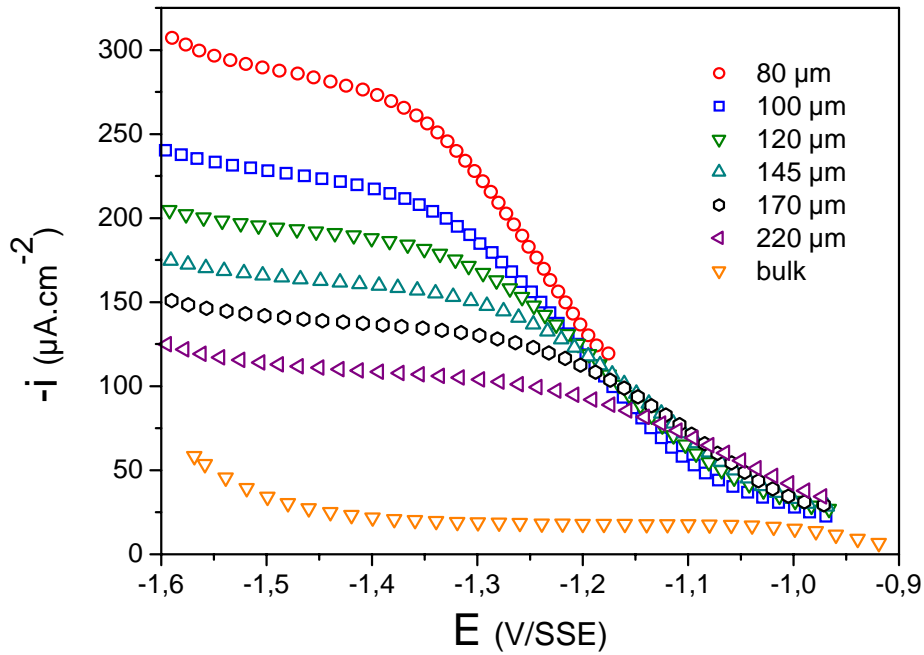

*Figure 7 : Evolution with the electrolyte film thickness of the quasi-stationary polarisation curves plotted in the oxygen reduction domain*

A rise of the oxygen limiting reduction current is observed when the average electrolyte film thickness decreases. Hence, in the case of a 80  $\mu\text{m}$  electrolyte film, the limiting oxygen reduction current is about 12 times higher than the current measured in bulk conditions.

A simple way to model mass transport in the thin layer cell can be proposed by neglecting any convective effects in the confined liquid film. With this assumption, the theoretical oxygen limiting current can be expressed as a pure diffusive current following (1) :

$$i_L = \frac{D_{O_2} \cdot C^*}{e} \quad (1)$$

With  $i_L$  the oxygen reduction limiting current;  $D_{O_2}$  the oxygen diffusion coefficient  
 $C^*$  the oxygen concentration at the membrane-electrolyte interface  
 $e$  the average electrolyte film thickness

The theoretical current was calculated by considering  $C^*$  equal to the equilibrium  $O_2$  concentration in water (pressure drop across the membrane was neglected). The constants used in the calculation were  $D_{O_2} = 2.2 \cdot 10^{-5} \text{ cm}^2 \cdot \text{s}^{-1}$  and  $C^* = 2.5 \cdot 10^{-7} \text{ mol} \cdot \text{cm}^{-3}$ . The experimental limiting currents were measured at  $-1.5 \text{ V/SSE}$  and corrected from the hydrogen evolution kinetic current measured at the same potential in bulk conditions. The inverses of the theoretical (calculated from (1)) and the experimental oxygen reduction limiting currents are plotted versus the electrolyte film thickness in figure 8.

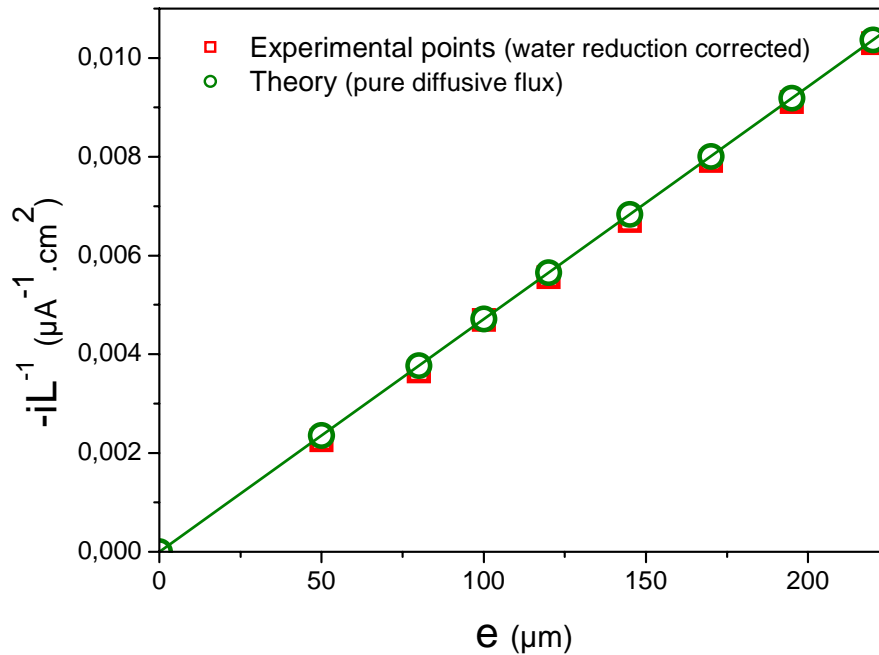

*Figure 8 : Comparison between calculated and measured oxygen reduction limiting currents*

A quasi perfect agreement between model and experience is obtained in the range of electrolyte film thickness investigated (50-220  $\mu\text{m}$ ). Because of the high sensitivity of the calculated currents to the electrolyte film thickness and to the oxygen concentration at the membrane-electrolyte interface, the results presented in figure 8 validate both the gas supply device and the positioning procedure. These results also validate the theoretical expression of the oxygen limiting mass transport current (1) and further demonstrate the absence of any significant convective contribution in the mass transport fluxes in thin layer cells.

#### IV. CONCLUSION

In order to investigate the influence of confinement on the corrosion behaviour of metallic materials, an innovative thin layer electrochemical cell was designed. This cell includes a gas supply device which insures a continuous and well controlled gas supply within the electrolyte film covering the specimen studied. A methodology based on high frequency impedance measurements, which allows a precise control and adjustment of the electrolyte film geometry, was also developed. Thanks to this method, errors of parallelism could be minimized and the liquid film average thickness can be set with an accuracy of  $\pm 10 \mu\text{m}$ .

The experimental setup was validated by performing measurements of stationary limiting cathodic current on a steel disk shaped specimen immersed in a  $\text{K}_2\text{SO}_4$  aerated solution for various electrolyte film thicknesses. The quasi-perfect agreement between theory and experimental measurements demonstrates the efficiency of the gas supply device and the high accuracy of the positioning procedure. Our results also show that convective contributions can be neglected in still and confined liquid film of thicknesses lower than  $250 \mu\text{m}$ .

This work, which led to the development of an innovative thin-layer electrochemical cell, provides a basis for further studies dealing with the corrosion behaviour of steels in confined electrolytes as for instance acidic aqueous solution encountered in the oil and gas industry.

#### REFERENCES

- [1] D. Festy, D. Choqueuse, D. Leflour, V. Lepage, C. Taravel-Condât, N. Desamais, B. Tribollet, Eurocorr 2004, paper 16-O-256, Nice (2004).
- [2] F. Ropital, C. Condât-Taravel, J. N. Saas, C. Duret, Eurocorr 2000, paper C014/55, London, (2000).
- [3] M. Keddam, A. Hugot-Le-Goff, H. Takenouti, D. Thierry, M. C. Arevalo, Corros. Sci. **33**, 1243, (1992).
- [4] C. Taravel-condat, N. Desamais, Conference OMAE 2006, Paper 92394, Hambourg, (2006)
- [5] C. Taravel-condat, N. Desamais, "Qualification of very high strength carbon steel wires for use in flexible pipes with presence of small amount of  $\text{H}_2\text{S}$ ", Eurocorr 2006, Maastricht, (2006).
- [6] M. Stratmann, H. Streckel, K. T. Kim, S. Crockett, Corros. Sci. **30**, 715, (1990)
- [7] C.R. Christensen, F. C. Anson, Anal. Chem. **35**, 205, (1963)
- [8] C. Fiaud, M. Keddam, A. Kadri, H. Takenouti, Electrochim. Acta, 32, 445, (1987).
- [9] C. Gabrielli, F. Huet, M. Keddam, P. Rousseau, V. Vivier, J. Phys. Chem. B **108**, 11620, (2004).