

## Benchmarking of the DMX TM CO 2 Capture Process

Paul Broutin, Patrick Briot, S. Ehlers, A. Kather

► **To cite this version:**

Paul Broutin, Patrick Briot, S. Ehlers, A. Kather. Benchmarking of the DMX TM CO 2 Capture Process. Energy Procedia, Elsevier, 2017, 114, pp.2561 - 2572. 10.1016/j.egypro.2017.03.1414 . hal-01740300

**HAL Id: hal-01740300**

**<https://hal-ifp.archives-ouvertes.fr/hal-01740300>**

Submitted on 4 Jan 2019

**HAL** is a multi-disciplinary open access archive for the deposit and dissemination of scientific research documents, whether they are published or not. The documents may come from teaching and research institutions in France or abroad, or from public or private research centers.

L'archive ouverte pluridisciplinaire **HAL**, est destinée au dépôt et à la diffusion de documents scientifiques de niveau recherche, publiés ou non, émanant des établissements d'enseignement et de recherche français ou étrangers, des laboratoires publics ou privés.





13<sup>th</sup> International Conference on Greenhouse Gas Control Technologies, GHGT-13, 14-18  
November 2016, Lausanne, Switzerland

## Benchmarking of the DMX<sup>TM</sup> CO<sub>2</sub> Capture Process

P Broutin<sup>a\*</sup>, P Briot<sup>a</sup>, S Ehlers<sup>b</sup>, A Kather<sup>b</sup>

<sup>a</sup> IFP Energies nouvelles, BP 3, F-69360 Solaize, France

<sup>b</sup> TUHH, Institute of Energy Systems, Denickestraße 15, D-21073 Hamburg, Germany

---

### Abstract

This paper presents the main results of Task 13.4 of the OCTAVIUS project dedicated to the benchmarking of DMX<sup>TM</sup> versus MEA 30 wt. % CO<sub>2</sub> capture processes.

In the introduction are given the main objectives of the FP7 Project OCTAVIUS, which ended in June 2016. In this first part are also presented the main characteristics of the DMX<sup>TM</sup> process developed by IFP Energies nouvelles (IFPEN) and licensed by PROSERMAT, which uses a phase change solvent.

The benchmarking study takes into account the design and the optimal integration of the CO<sub>2</sub> capture process within the power plant and the CO<sub>2</sub> compression at 110 bara. The thermal integration has been realised by TUHH. The design and evaluation of the capture processes were carried out by IFPEN based on the results of mini-pilots experimentation within OCTAVIUS and of previous works. The comparison has been performed for a reference power plant (805 MW<sub>e</sub> coal power station) using criteria defined jointly with the industrial partners of the OCTAVIUS project.

This techno-economic study confirms that the DMX<sup>TM</sup> process is very promising as it allows a reduction in energy penalty compared to the MEA reference process without Lean Vapour Compression by approximately 2 % points. As a consequence, it gives lower Cost of Electricity and lower avoided CO<sub>2</sub> cost: 42.6 €/tCO<sub>2</sub> (56.5 €/tCO<sub>2</sub> for the MEA reference process).

The DMX<sup>TM</sup> process needs now to be demonstrated in an industrial scale pilot plant.

© 2017 The Authors. Published by Elsevier Ltd. This is an open access article under the CC BY-NC-ND license (<http://creativecommons.org/licenses/by-nc-nd/4.0/>).

Peer-review under responsibility of the organizing committee of GHGT-13.

**Keywords:** CO<sub>2</sub> capture ; amines based solvents ; MEA ; DMX; two-phase solvents ; process evaluation ; benchmark

---

\* Corresponding author. Tel.: +33 4 37 70 26 97; fax: 33 4 37 70 20 15.

E-mail address: [paul.broutin@ifpen.fr](mailto:paul.broutin@ifpen.fr)

## 1. Introduction

CO<sub>2</sub> Capture and geological Storage is now recognised as being one of the pathways that can be implemented to reduce CO<sub>2</sub> emissions and fight global warming.

Among all possible technologies for CO<sub>2</sub> capture from flue gases generated at power stations, first-generation post-combustion processes using amine-based solvents appear as the most developed for middle term industrial deployment. Full scale demonstration projects planned in Europe, such as the ROAD project, will implement such first generation processes which were studied within the previous FP6 and FP7 projects CASTOR [1,2,3] and CESAR [4]. Within these projects, process upgrades and novel solvents were evaluated at pilot-scale [5].

One of the aims of the FP7 project OCTAVIUS [6,7,8] was to continue these developments on first generation CO<sub>2</sub> post-combustion processes. Operability and flexibility of these CO<sub>2</sub> capture processes were demonstrated on three industrial pilot plants (TNO pilot plant in Maasvlakte (NL), ENEL pilot plant in Brindisi (IT) and EnBW pilot plant in Heilbronn (DE)). Within OCTAVIUS were established detailed guidelines for the first full scale demonstration projects.

The plan was also to demonstrate on the ENEL pilot plant the DMX<sup>TM</sup> process. Nevertheless, due to a higher cost than initially expected for the revamp of this industrial pilot plant, it was not possible to perform this demonstration within OCTAVIUS.

The DMX<sup>TM</sup> process [9,10] developed by IFP Energies nouvelles (IFPEN) and licensed by PROSERMAT is a second-generation CO<sub>2</sub> capture process using a phase change solvent.

Main advantages of the DMX<sup>TM</sup> process are:

- Higher cyclic capacity than MEA: from 0.1 to 1 mol CO<sub>2</sub>/mol solvent which allows very low solvent flow rate and by consequence lower heat required for regeneration (less than 2.5 GJ/tCO<sub>2</sub>).
- No degradation of the DMX<sup>TM</sup> solvents (up to 160°C): so regeneration can be operated under pressure and CO<sub>2</sub> may be produced at higher pressure (up to 6-7 bara).
- The DMX<sup>TM</sup> solvent is not corrosive: Carbon Steel may be used as material for the DMX<sup>TM</sup> process.
- Same CAPEX as for first-generation processes.
- But up to 30 % reduction in OPEX.

Experimentation on minipilots and techno-economic evaluation within subproject SP3 of OCTAVIUS have confirmed its potential in terms of reduction of energy penalty and operational costs.

This paper presents the main results obtained within Task 13.4 of the OCTAVIUS project dedicated to the benchmarking of DMX<sup>TM</sup> versus MEA 30 wt. % CO<sub>2</sub> capture processes.

## 2. Bases of the Benchmark Study

The comparison has been performed based on a reference bituminous coal power plant using criteria defined jointly with the industrial partners of the project [11]. This power plant is a single advanced supercritical unit with an electric gross power output of 804.8 MW<sub>e</sub>. With an auxiliary power consumption of 61.3 MW<sub>e</sub> the net power output equals 743.5 MW<sub>e</sub>. Thus the determined net cycle efficiency at full load operation is 45.4% related to LHV while the specific CO<sub>2</sub> emission is 761.5 g/kWh<sub>net</sub> without post-combustion CO<sub>2</sub> capture. A schematic flow diagram of the power plant is shown in Fig. 1.

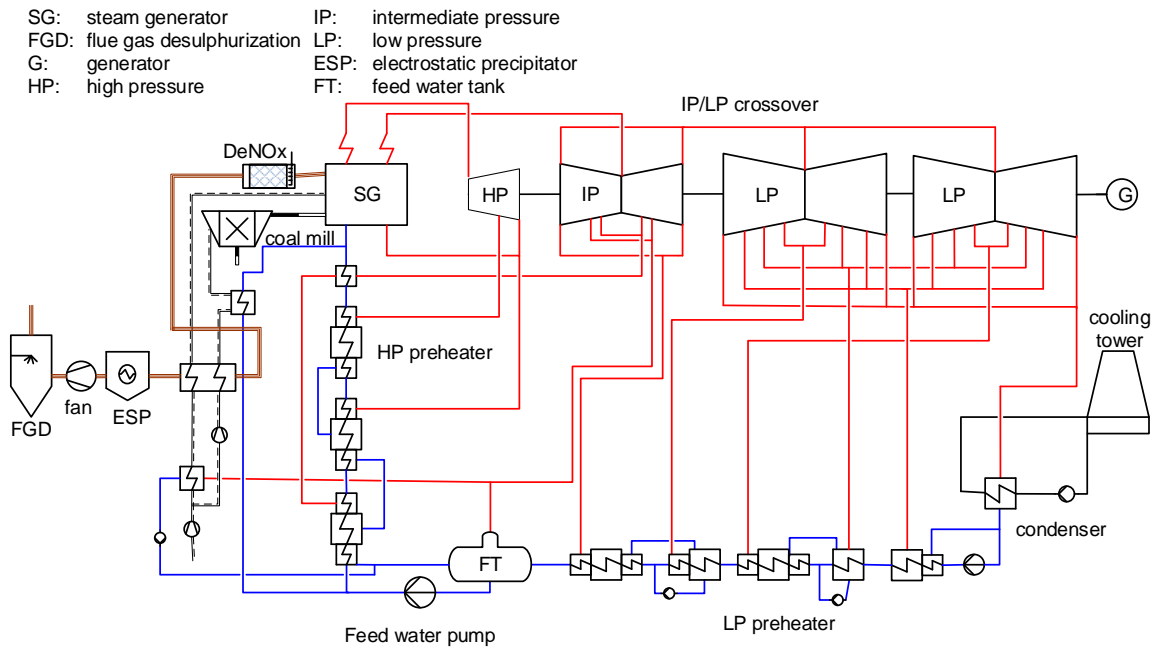

Fig. 1: Flow diagram of the reference plant

The live steam leaves the boiler at 300 bars and 600 °C and is expanded in a single high pressure turbine. Afterwards, it is reheated and expanded in a double-flow intermediate pressure turbine. In two double-flow low pressure turbines the steam is expanded to 0.048 bar condenser pressure. The feed water preheating train consists of six LP preheaters (including the degasification in the feed water tank) and three HP preheaters.

The fresh air for combustion is split in two separate streams. The primary air is used downstream of the air preheater for preheating a split stream of the feed water. Afterwards it is used as mill air. The secondary air is sent directly into the combustion chamber. The flue gas is cleaned in a DeNOx unit, an electrostatic precipitator and finally a flue gas desulphurisation unit.

The cooling system consists of a natural draught cooling tower, which supplies cooling water at 18.2 °C. The temperature gain in the condenser is assumed to be 11 °C. With a condenser pinch of 3 K the temperature of the condensing steam equals 32.2 °C with a corresponding condenser pressure of 0.048 bar.

An efficiency of 80 % for all pumps is used. For the steam turbine, the isentropic efficiencies are taken as follows:  $\eta_{HP} = 92\%$ ,  $\eta_{IP} = 94\%$ ,  $\eta_{LP} = 88\%$ .

The exhaust loss of the LP turbine is included directly (30 kJ/kg). Losses due to moisture are incorporated using the Baumann Correlation with a Baumann factor of 0.9. Electrical efficiency is assumed to be 97% and mechanical efficiency 99.8%.

As fuel the Bituminous Douglas Premium Coal is used. Its LHV is 25.2 MJ/kg. The conditions of the flue gas leaving the power plant and entering the capture plant are given in Table 1.

Table 1: Flue gas conditions for the reference plant

<b>Mass flow rate (kg/s)</b>	786.5
<b>Temperature (°C)</b>	50.3
<b>Pressure (kPa)</b>	101.6
<b>Composition (vol.%)</b>	
CO <sub>2</sub>	13.25
O <sub>2</sub>	3.65
H <sub>2</sub> O	12.11
Inert (Ar+N <sub>2</sub> )	70.99
(SO <sub>x</sub> and NO <sub>x</sub> are omitted here)	

This benchmarking study takes into account the design and the optimal integration of the CO<sub>2</sub> capture process within the power plant and the CO<sub>2</sub> compression at 110 bara. Figure 2 presents the thermal integration considered by TUHH. Steam is extracted from the IP/LP crossover to provide heat for solvent regeneration. For the CO<sub>2</sub> Capture Plant, the LP steam is used for the solvent regeneration to feed the strippers' reboilers. The IP/LP crossover is the most convenient place for steam extraction. The LP steam extraction pipe leads to a pressure loss of 5%. The reboiler condensate is returned to the power plant cycle. The exact position depends on the temperatures of the mixed condensate streams. In addition, waste heat from the capture plant and the CO<sub>2</sub> compressor is used to heat up part of the condensate.

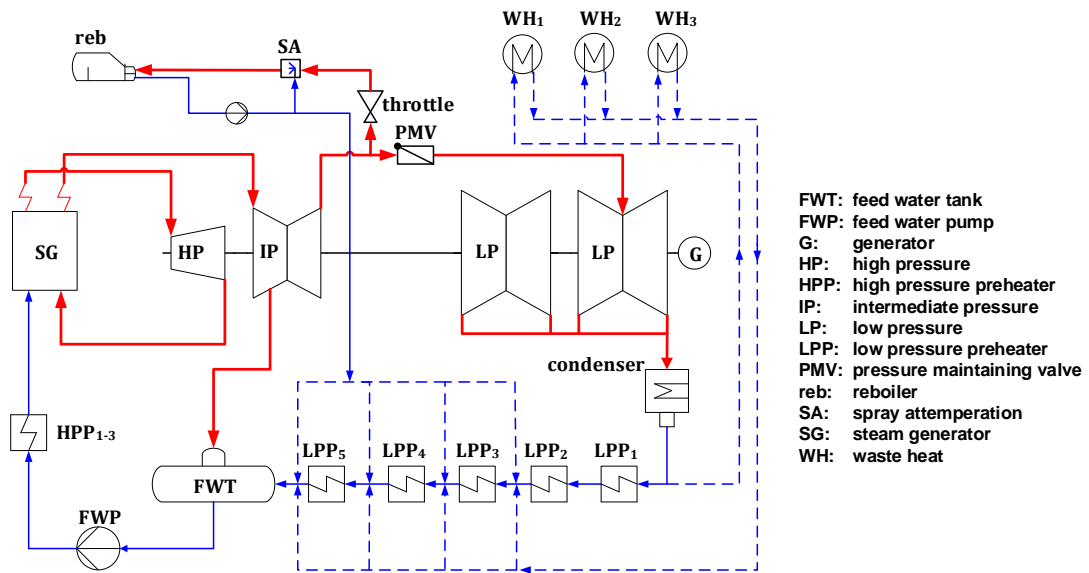

Fig. 2. Thermal Integration of the CO<sub>2</sub> capture process within the reference power plant

The design and evaluation of the capture processes carried out by IFPEN are based on the results of mini-pilots experimentation within OCTAVIUS [12] and of previous works at IFPEN.

For the MEA 30 wt. % process two cases have been considered: without and with Lean Vapour Compression (LVC) from 1.1 to 1.9 bara.

For the DMX<sup>TM</sup> process two cases have been considered as well, with two extreme regeneration pressures: High Pressure (HP) = 6.25 bara and Low Pressure (LP) = 1.85 bara. With the HP case, the CO<sub>2</sub> is produced at 6 bara, which correspondingly reduces the further work required for compression up to 110 bara.

For CO<sub>2</sub> compression an integrally geared (radial) compressor with six stages, three inter-coolers and one after-cooler has been considered (see Figure 3). The intercooling temperature is 40 °C. CO<sub>2</sub> being wet, a dehydration is required due to the risk of pipeline corrosion and hydrates formation during transportation of the pressurised CO<sub>2</sub> stream. Such dehydration has been considered between the 4<sup>th</sup> and 5<sup>th</sup> stage.

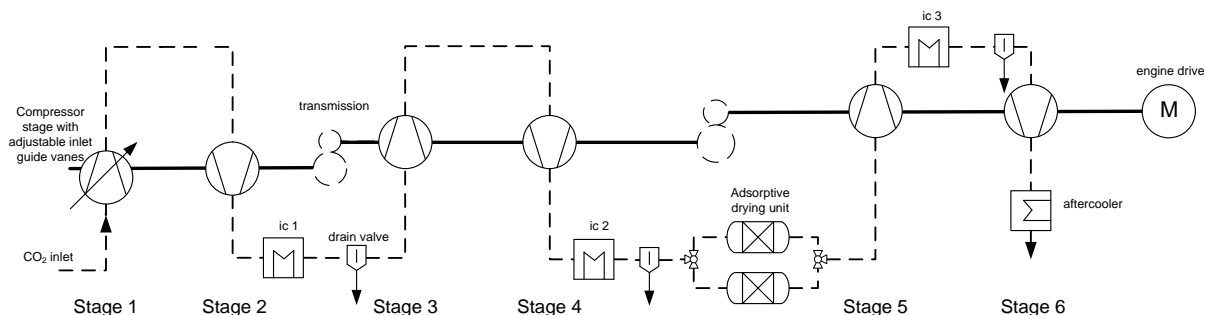

Fig. 3. Flow Sheet of CO<sub>2</sub> compression

The methodology used for the evaluation is according to the same lines as described in the CESAR-EBTF work [13]. The basis for costs in OCTAVIUS is the year 2012.

The following tools have been used within this study:

- the commercial software tool EBSILON<sup>®</sup> Professional 9.00, for the power plant simulations by TUHH;
- the commercial software tool Aspen Plus (with the RateSep column model and in-house modules), for simulation by IFPEN of the capture processes with MEA solvent;
- the commercial software Pro II, with proprietary thermodynamic and reactions models included in a User Added Subroutine (UAS), for simulation by IFPEN of the DMX<sup>TM</sup> process;
- the in-house software Estime 8.1, for estimation by IFPEN of the Purchased Equipment Costs. This software is based on the Chauvel methodology [14].

### 3. Main Results

#### 3.1. Design of the Capture Plant

Figures 4 to 6 present the flow diagrams for the studied processes: MEA with and without LVC and DMX™.

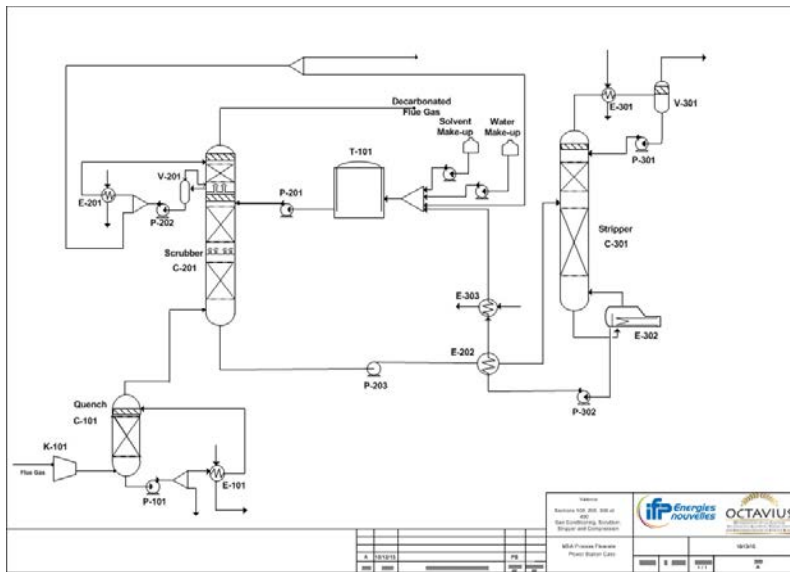

Fig. 4: Flow diagram of the CO<sub>2</sub> Capture Plant for the MEA process without LVC

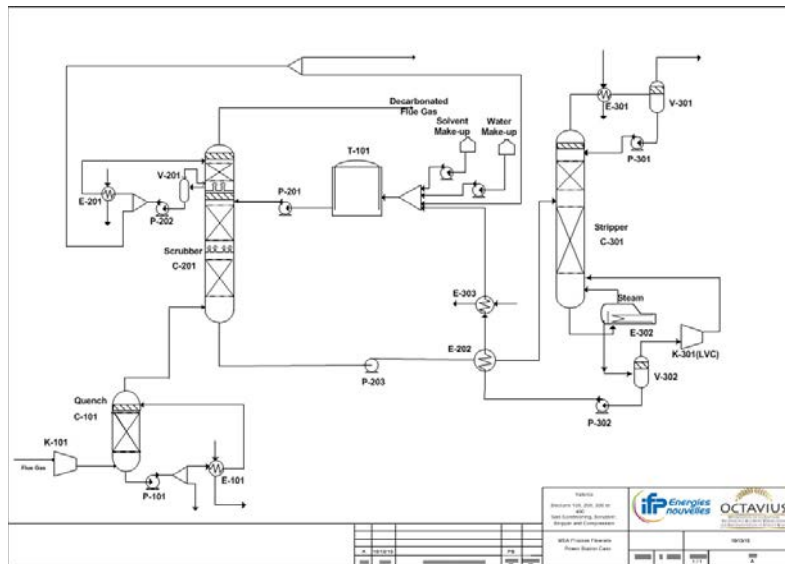

Fig. 5: Flow diagram of the CO<sub>2</sub> Capture Plant for the MEA with LVC process

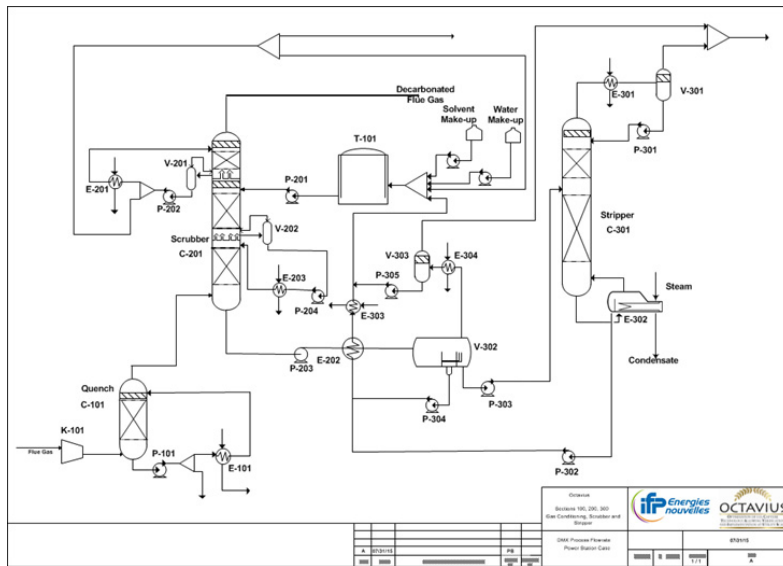

Fig. 6: Flow diagram of the DMX™ CO<sub>2</sub> Capture process

For the DMX™ process additional equipment is needed:

- An intercooler in the absorber to decrease the amine temperature during the capture,
- A flash tank called decanter where, under appropriate conditions of loading, temperature and pressure, the rich amine can be dissociated in three flows:
  - a gas phase containing mainly CO<sub>2</sub> and water,
  - a light liquid phase containing mainly amine and water and mostly exempted of CO<sub>2</sub>. This phase is not sent to the stripper column but is returned to the storage tank,
  - a heavy liquid phase containing CO<sub>2</sub>, amine and water which is sent to the stripper column.

The resulting designs of the different columns for all the processes are presented in Table 2.

Since part of CO<sub>2</sub> and solvent are not sent to the stripper, the stripper column size is smaller with DMX™ solvent than with MEA solvent. Part of the equipment may be in Carbon Steel. So at the end, the CAPEX for DMX™ process is the same as for MEA process without LVC.

The blower outlet pressure was based on an outlet absorber pressure of 1.04 bara so slightly higher than atmospheric pressure.

As the DMX™ processes require a higher height of packing than MEA, the blower works for DMX™ processes are higher (~ 17 MW) than the ones for MEA processes (~ 16 MW); see Table 3.

The calculation of the CO<sub>2</sub> compressor duty is based on the bottom stripper pressure as shown in the Table 4.

As the CO<sub>2</sub> pressure at the inlet of the compressor and the amount of CO<sub>2</sub> are nearly the same, the compressor duties are the same for the three processes. The only exception is for DMX™ at high pressure as the CO<sub>2</sub> at suction of the compressor is at 6 bara, so the duty required to compress it to 110 bara is much lower than for the other studied processes.



Table 2: Columns designs for the different CO<sub>2</sub> Capture Processes

Process	MEA (No LVC)	MEA (with LVC )	DMX (HP)	DMX (LP)
<b>Number of trains</b>	4	3	2	3
<b>Quench Tower (DCC)</b>				
Diameter (m)	7.8	9	12.5	10.5
Packing Height (m)	7	7	5	5
Material	316L	316L	316L	316L
<b>Absorber</b>				
Diameter (m)	11.4	13.2	12.5	10.5
Packing Height (m)	27	30	45	45
Material	316L	316L	316L	316L
<b>Regenerator</b>				
Diameter (m)	5.8	7	6.9	6.2
Packing Height (m)	28	21.5	12	12.2
Material	316L	316L	CS	CS

Table 3: Pressure drops and Blower works for the CO<sub>2</sub> capture processes

Process	MEA (No LVC)	MEA (with LVC )	DMX (HP)	DMX (LP)
Outlet absorber Pressure (bara)	1.04	1.04	1.04	1.04
Total pressure Drop (mbar) (DCC+Absorber)	186	194	224	222
Blower Outlet Pressure (bara)	1.226	1.234	1.264	1.282
<b>Total Blower Work (MWe)</b>	<b>16.1</b>	<b>16.4</b>	<b>17.2</b>	<b>17.2</b>

Table 4: Calculation of CO<sub>2</sub> compressor work for the different processes

Process	MEA (No LVC)	MEA (with LVC )	DMX (HP)	DMX (LP)
Bottom Stripper Pressure (bara)	1.91	1.91	6.25	1.85
Stripper pressure Drop (mbar)	85	57	19	35
Stripper Overhead Pressure (bara)	1.83	1.85	6.23	1.82
HX Pressure Drop (mbar)	55	56	187	54
CO <sub>2</sub> compressor Suction Pressure (bara)	1.77	1.79	6.04	1.76
CO <sub>2</sub> compressor Discharge Pressure (bara)	110	110	110	110
<b>Total CO<sub>2</sub> Compressor Work (MWe)</b>	<b>51.5</b>	<b>50.9</b>	<b>34.9</b>	<b>53</b>

### 3.2. Integration with the Power Plant

The most important result of the integration of the capture plant within the power plant is the net efficiency penalty. It is defined as the difference between the net efficiency of the reference power plant without CO<sub>2</sub> capture and the net efficiency of the power plant with CO<sub>2</sub> capture. This value incorporates the different effects that the capture process has on the power plant and can thus be used to compare processes in terms of energy efficiency. Other values which are sometimes used as comparison between processes, like the specific reboiler duty, are not suitable for this purpose, since an increased electric duty or a higher reboiler temperature can outweigh the positive effect of a lower reboiler duty. The efficiency penalty for all four cases is shown in Table 5. To be able to see the influence of different effects on the overall efficiency penalty, the penalty is split into the different contributors explained in the following.

Table 5: Contributors to overall efficiency penalty for the four evaluated cases

Process	MEA (No LVC)	MEA (with LVC )	DMX (HP)	DMX (LP)
Efficiency penalty due to ...				
steam extraction	6.90 %-pts.	5.60 %-pts.	5.87 %-pts.	4.79 %-pts.
CO <sub>2</sub> compressor duty	3.29 %-pts.	3.29 %-pts.	2.31 %-pts.	3.31 %-pts.
auxiliary power duty	1.43 %-pts.	2.04 %-pts.	1.67 %-pts.	1.60 %-pts.
cooling water duty	0.38 %-pts.	0.29 %-pts.	0.22 %-pts.	0.27 %-pts.
heat integration	-0.72 %-pts.	-0.76 %-pts.	-0.69 %-pts.	-0.71 %-pts.
<b>Overall efficiency penalty</b>	<b>11.28 %-pts.</b>	<b>10.46 %-pts.</b>	<b>9.38 %-pts.</b>	<b>9.25 %-pts.</b>

The penalty due to steam extraction is the largest contributor in all cases. It depends on the specific reboiler duty as well as on the pressure of the extracted steam. The influence of the steam pressure gets most obvious when comparing the two DMX<sup>TM</sup> cases. The specific reboiler duty for the case with higher reboiler pressure is slightly lower compared to the case with lower reboiler pressure. Still, the efficiency penalty due to steam extraction is more than 1 %-point higher in the high pressure case. This is due to the required pressure of extracted steam (6.6 bar for HP case, 2.4 bar for LP case). The comparison of the two MEA cases confirms the advantage of the LVC case in terms of steam demand of the capture process.

Since the amount of CO<sub>2</sub> captured is identical in all cases, the efficiency penalty due to CO<sub>2</sub> compressor duty depends only on the stripper overhead pressure. Its value is almost identical for the MEA cases and the LP DMX<sup>TM</sup> case, but significantly lower for the HP DMX<sup>TM</sup> case (cf. Table 4). Due to the high pressure, two compression stages can be omitted, resulting in a much lower compressor duty and thus more than 1 %-point less efficiency penalty.

The efficiency penalty due to auxiliary power duty incorporates the electric duty of the flue gas blower, all pumps and the LVC. The latter is responsible for the highest penalty seen for the MEA case with LVC. Both DMX<sup>TM</sup> cases show a slightly higher auxiliary power duty due to taller absorbers (cf. Table 2), resulting in increased blower and pump duties.

The cooling demand of some heat exchangers in the capture plant leads to additional cooling water pump duty. It correlates with the amount of heat that is transferred into the capture plant in the reboiler, but has only a small effect on the efficiency penalty for all cases.

The heat integration in Table 5 is given as negative value and thus reduces the overall efficiency penalty. There are only small differences between the four cases. For all cases, the overhead condenser and the CO<sub>2</sub> compressor intercoolers are used as heat source for waste heat integration. The positive effect for the HP DMX<sup>TM</sup> case is smallest, since the intercoolers for the CO<sub>2</sub> compressor provide significantly less heat. This is due to the reduced number of compression stages. Part of the condensate in the power plant has to be preheated by means of conventional feed water preheaters for this case. For the other three cases, it is possible to provide enough heat to preheat the whole condensate mass flow. The MEA case with LVC benefits most from heat integration, since the amount of condensate in the first preheaters is higher compared to the MEA case without LVC (215 kg/s compared to 175 kg/s). This is because less steam is extracted for the reboiler when LVC is used. For the LP DMX<sup>TM</sup> case even more condensate is coming from the condenser (228 kg/s), but the temperature level in the overhead condenser is significantly lower (80 °C compared to around 100 °C for MEA cases).

In total, the DMX<sup>TM</sup> cases show a potential for more than 2 %-points less efficiency penalty compared to the MEA case with LVC. The DMX<sup>TM</sup> case with low pressure stripper has a slightly smaller penalty, but the difference is very small and might vary depending on the actual process design.

### 3.3. Techno-economic Evaluation

Tables 6 to 8 give the comparison of the four studied processes in terms of energy penalty, CAPEX, Cost of Electricity and cost of avoided CO<sub>2</sub>.

Table 6: Energy penalty after heat integration

Process	Power Plant (without capture)	PP + MEA (No LVC)	PP + MEA (with LVC)	PP + DMX (HP)	PP + DMX (LP)
IP/LP Crossover (bara)	5.76	2.895	2.895	6.584	2.42
Net Elect. Production (MW <sub>e</sub> )	743.5	559.0	572.3	592.2	592.5
Net Efficiency (%)	45.42	34.14	34.96	36.04	36.17
<b>Efficiency penalty (% points)</b>		<b>- 11.28</b>	<b>- 10.46</b>	<b>- 9.38</b>	<b>- 9.25</b>

Table 7: Capital Expenditure (CAPEX)

Process	Power Plant (without capture)	PP + MEA (No LVC)	PP + MEA (with LVC)	PP + DMX (HP)	PP + DMX (LP)
P.E.C (Purchased Equipment Cost) (M€)	607.6	746.9	752.3	719.3	737.2
CAPEX (M€)	1745.4	2150.9	2166.4	2087	2138.4
<b>CAPEX Increase (%)</b>		<b>+ 23.2</b>	<b>+ 24.1</b>	<b>+ 19.6</b>	<b>+ 22.5</b>

Table 8: Cost of Electricity (COE) and CO<sub>2</sub> avoided Cost

Process	Power Plant (without capture)	PP + MEA (No LVC)	PP + MEA (with LVC)	PP + DMX (HP)	PP + DMX (LP)
CO <sub>2</sub> Emissions (ton/MWh)	0.76	0.08	0.09	0.08	0.07
C.O.E. (€/MWh)	61.18	99.05	97.09	89.89	91.72
COE Increase (%)		+ 61.9	+ 58.7	+ 46.9	+ 49.9
<b>CO<sub>2</sub> avoided Cost (€/CO<sub>2</sub> ton)</b>		<b>56.45</b>	<b>54.30</b>	<b>42.55</b>	<b>44.46</b>

Table 6 compares the processes in terms of energy penalty. CO<sub>2</sub> capture based on MEA 30 wt. % leads to a penalty on the Power Plant of 11.3 % points. The LVC process, despite its higher electricity consumption, confirms its positive influence with a lower penalty than MEA reference process (10.46 % points). Nevertheless, DMX<sup>TM</sup> processes have the lowest penalty on the power plant (9.25 and 9.36 % points) so 2 % points lower than the reference MEA process without LVC.

With the CO<sub>2</sub> capture integrated into the power plant, the CAPEX increases by approximately 20%: the lowest CAPEX increase is 19.6% for DMX<sup>TM</sup> at high pressure and the highest 24.1% for MEA with LVC (see Table 7).

Table 8 compares the processes in terms of Cost of Electricity and avoided CO<sub>2</sub> cost. For MEA processes, the Lean Vapour Compression process confirms its positive influence compared to the reference MEA process (- 2 €/MWh on C.O.E. and - 2 €/CO<sub>2</sub> ton on CO<sub>2</sub> avoided Cost). For DMX<sup>TM</sup> processes, the high stripping pressure case is more interesting than the low stripping pressure case (- 2 €/MWh on C.O.E. and - 2 €/CO<sub>2</sub> ton on CO<sub>2</sub> avoided Cost). The DMX<sup>TM</sup> process is very promising as it gives lower Cost of Electricity and lower avoided CO<sub>2</sub> cost: 42.6 €/CO<sub>2</sub> ton for the HP case (56.5 €/CO<sub>2</sub> ton for the MEA reference process).

#### 4. Conclusions

This benchmarking study is based on design and optimal integration of the CO<sub>2</sub> capture process within the power plant. The comparison of the four CO<sub>2</sub> capture processes shows that the DMX<sup>TM</sup> Capture Process at high stripper pressure has the lowest electricity and steam consumptions.

As the different capture processes use LP steam with different temperatures, the steam cycle was designed in order to have the pressure level at the outlet of IP turbine adapted to the CO<sub>2</sub> Capture Process. Part of the waste heat from the capture processes was used to pre-heat the power plant condensate.

The results of these integrations show that the DMX<sup>TM</sup> process allows a reduction in energy penalty compared to the MEA base process without Lean Vapour Compression by approximately 2 % points. Adding Lean Vapour Compression in the MEA process reduces energy penalty by only 1 % point.

In terms of CAPEX, the CO<sub>2</sub> capture integrated to a power plant leads to CAPEX increase around 20%: the lowest 19.6% for DMX<sup>TM</sup> at high pressure and the highest 24.1% for MEA with LVC technology.

The high pressure stripping case gives the lower Cost of Electricity and the lower avoided CO<sub>2</sub> cost: 42.6 €/CO<sub>2</sub> ton (56.5 €/CO<sub>2</sub> ton for the MEA reference process).

So DMX<sup>TM</sup> process is very promising but it needs now to be demonstrated in an industrial scale pilot plant.

## Acknowledgements

This work has been performed within the EU FP7 project OCTAVIUS (Grant Agreement n° 295645).

## References

- [1] Le Thiez P, Mosditchian G, Torp T, Feron P, Ritsema I, Zweigel P, Lindeberg E, An Innovative European Project: CASTOR – CO<sub>2</sub> from Capture to Storage, Poster presented at GHGT-7, Vancouver, 2004.
- [2] Le Thiez P, Lindeberg E, Feron P, CASTOR – CO<sub>2</sub> from Capture to Storage: overview of results obtained after 18 months, Oral presentation at GHGT-8, Trondheim, 2006.
- [3] Broutin P, CASTOR: what have we learnt, way forward, Oral presentation at CO2NET 2008 Annual Seminar, Warsaw, 22-24 April 2008.
- [4] Van Os P, CESAR CO<sub>2</sub> Enhanced Separation And Recovery Overview of CESAR Results, CCS Research and Development to Implementation, London, United Kingdom, 24-26 May 2011.
- [5] Knudsen J, Andersen J, Jensen J, Biede O, Evaluation of process upgrades and novel solvents for the post-combustion CO<sub>2</sub> capture process in pilot-scale, Oral presentation at GHGT-10, Amsterdam, 2010, Energy Procedia 4 (2011) 1558 – 1565.
- [6] OCTAVIUS: Grant Agreement N° 295645.
- [7] Broutin P, Kvamsdal H, La Marca C, van Os P, Booth N, OCTAVIUS: a new FP7 project demonstrating CO<sub>2</sub> capture technologies, Poster presented at GHGT-11, Kyoto, 2012, Energy Procedia, 37 (2013) 6365 – 6373.
- [8] Broutin P, Kvamsdal H, La Marca C, van Os P, Robinson L, OCTAVIUS: a FP7 project demonstrating CO<sub>2</sub> capture technologies, Poster presented at GHGT-12, Austin, 2014, Energy Procedia, 63 (2014) 6194 – 6206.
- [9] Raynal L, Bouillon PA, Gomez A and Broutin P. From MEA to demixing solvents and future steps, a roadmap for lowering the cost of post-combustion carbon capture. Chem. Eng. J. 171 (2011) 742-752.
- [10] Raynal L, Alix P, Bouillon PA, le Febvre de Nailly M, Jacquin M, Kittel J, di Lella A, Mougin P and Trapy J. The DMX<sup>TM</sup> process: an original solution for lowering the cost of post-combustion carbon capture, Oral presentation at GHGT-10, Amsterdam, 2010, Energy Procedia 4 (2011) 779-786.
- [11] Kvamsdal H, Ehlers S, Khakharia P, Loldrup Fosbøl P, Liebenthal U, Sanchez Sanchez C, Haugen G, Chikukwa A, Robinson L, Booth N, Gomez A, Chopin F, A New Reference Case for Benchmarking in the OCTAVIUS project, Oral presentation at PCCC-2 conference, Bergen, 2013.
- [12] Raynal L, Briot P, Dreillard M, Broutin P, Mangiaracina A, Salghetti Drioli B, Politi M, La Marca C, Mertens J, Thielens ML, Laborie G, Normand L, OCTAVIUS: Evaluation of the DMX<sup>TM</sup> process for industrial pilot demonstration – methodology and results, Poster presented at GHGT-12, Austin, 2014, Energy Procedia 63 (2014) 6298 – 6309.
- [13] Booth N, and numerous co-authors, European Best Practice Guidelines for Assessment of CO<sub>2</sub> Capture Technologies, CESAR deliverable D23.4 (Public – download @ [www.co2cesar.eu](http://www.co2cesar.eu)), 2011.
- [14] Chauvel A, Fournier G, Raimbaut C, Manuel d'évaluation économique des Procédés, Book Published by Ed. Technip (2001).